

## **TRUSSES - HOW THEY WORK**

In the evolution of building there have been two great developments since man first used timber or stone to provide himself with shelter. These materials were first used as simple beams. The Romans are credited with the invention of the arch, and the truss was developed in Europe during the middle ages.

A beam supports loads due to its bending strength. This is the way simple members such as rafters, battens, purlins, lintels and bressummers work. The top edge of a beam is normally in compression and the bottom edge in tension. These stresses reach a maximum near the middle of the beam's span and for every doubling of span the strength of the beam must increase four times. Beams also tend to sag when loaded and sag is even more sensitive to increases in span than the requirement for increased strength.

The Romans found that if they leant stones against one-another in the shape of an arch, they could span greater distances than by using the stone as simple lintels or beams. In an arch the stones are in compression. The arch will perform as long as the supports or buttresses at each end of the arch provide restraint, and do not spread apart. Timber beams can also be propped against one-another to form arches. The timber members will be in compression and will also act as simple beams.

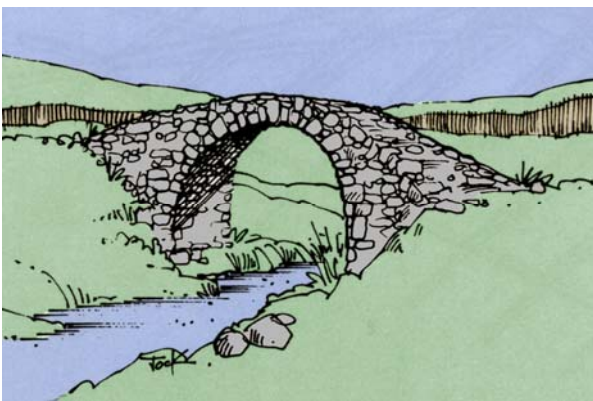

**Roman Arch Bridge**

To turn the arch into a truss, all that is required is to provide a tie between the two buttresses to stop them from being pushed apart by the arch. The arch, beam, tie combinations is self-supporting – we call this structure a truss.

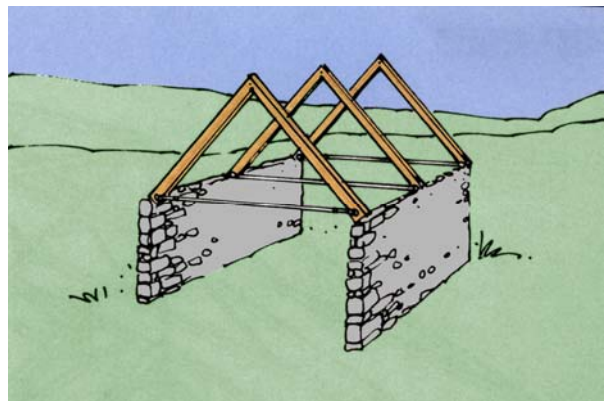

**Timber Arch**

Gang-Nail trusses are based on these simple structures. All the truss members are timber, and the joints between the members are formed using Gang-Nail connector plates.

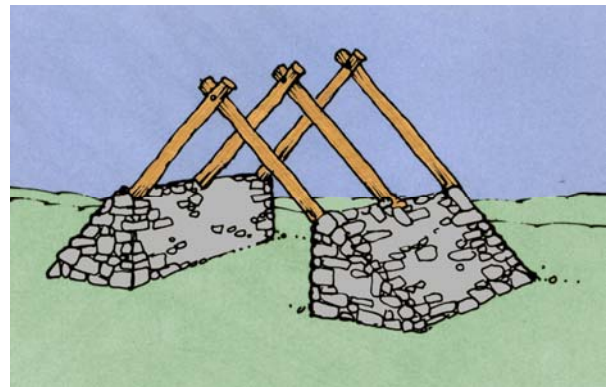

**Single Truss with Arched Rafter and Tie**

The characteristic appearance of a truss is a framework formed by many small triangles. A triangle is a naturally stable shape, compared with say a rectangular framework which can be deformed unless its joints are rigid or it is braced from corner to corner. Such a brace would, of course, convert a rectangle into two connected triangles on a truss. The members forming the perimeter of a truss – the chords – usually act as beams as well as ties or struts. The shorter the distance between truss joints, the smaller the chord section required.

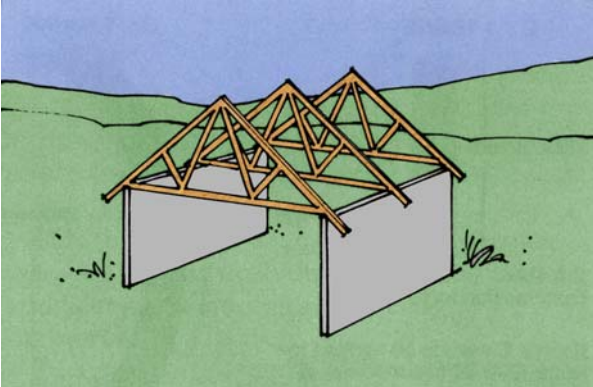

***Common "A" Type Gang-Nail Truss***

However, the more joints there are in the truss, the more expensive it is to fabricate. The designer of a truss can choose the arrangement of the chords and webs and must balance structural efficiency against manufacturing efficiency in supporting the applied loads.

## BASIC TRUSS MECHANICS

All trusses in a roof structure are designed for the worst possible combination of dead, live and wind loads. The individual truss members are designed to restrain the corresponding forces i.e., tension or compression, or a combination of bending with either the tension or compression force.

**Tension** (pulling). With this type of force the member being pulled or subjected to a tension force is said to be "in tension". The ability of a member to restrain tension forces depends on the material strength of the member and its cross-sectional area.

Figure 1

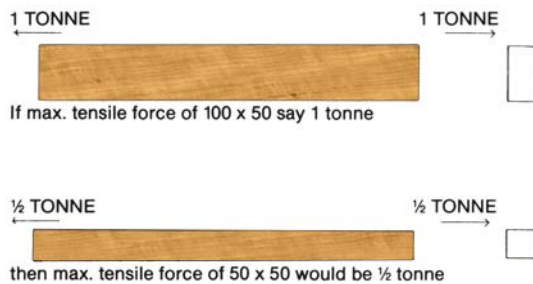

The example shows that if the cross-sectional area of a member is doubled, the ability of that member to restrain the tension forces is also doubled.

**Compression** (pushing). When a structural member is subjected to this type of force it is sometimes referred to as a column. Unlike a tension member, the ability of a column to restrain compression forces is not simply a function of the cross-sectional area, but a combination of the material strength, the column length and the cross-sectional shape of the column.

If one tonne is the maximum compression force that can be supported by a piece of 100 x 38 mm timber, 1200 mm long without buckling, then the same force applied to a piece of 100 x 38 mm timber, but twice as long, would certainly cause it to buckle and possibly collapse.

Figure 2

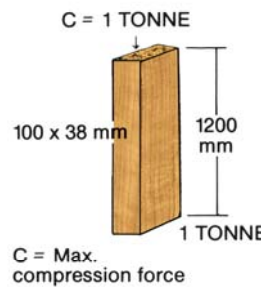
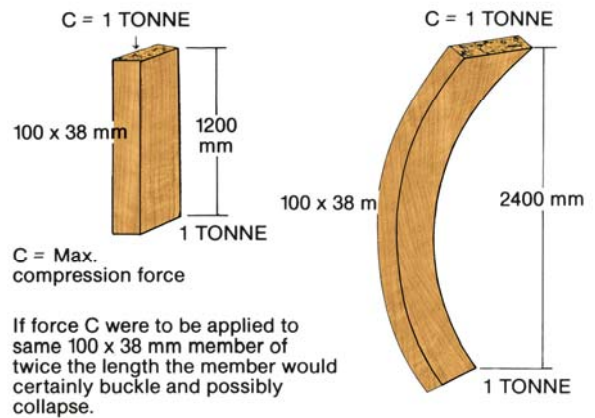
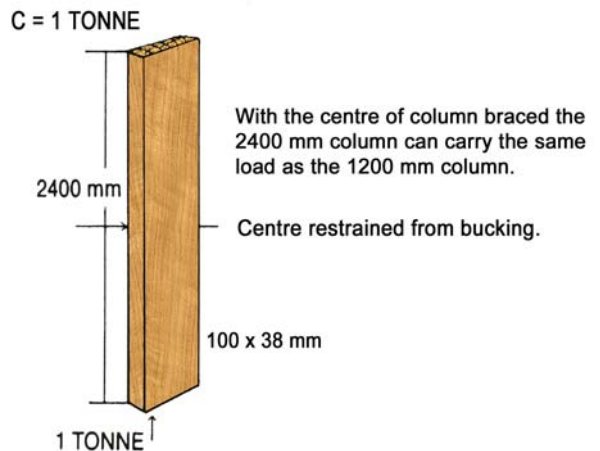

Figure 3



However, if we rigidly support the 2400 mm long column in the previous example at the centre, it would then be capable of withstanding the one tonne force.

Figure 4



Where this rigid support is applied to a web member, it is called a web tie, which is used in conjunction with bracing. (See Figure 5A)

Figure 5a

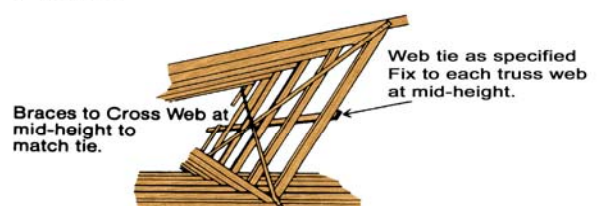

Battens with bracing from the rigid supports are needed to restrain the truss chords from buckling sideways. (See Figure 5b).

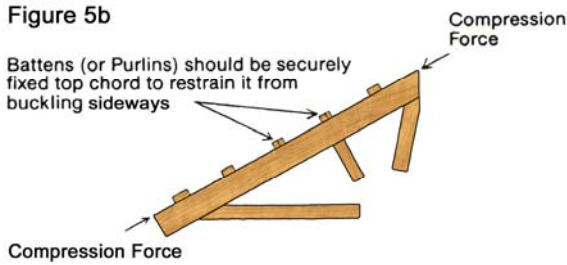

The strength of a column is also dependent on the cross-sectional shape of a column. The squarer or more symmetrical the shape, the stronger the

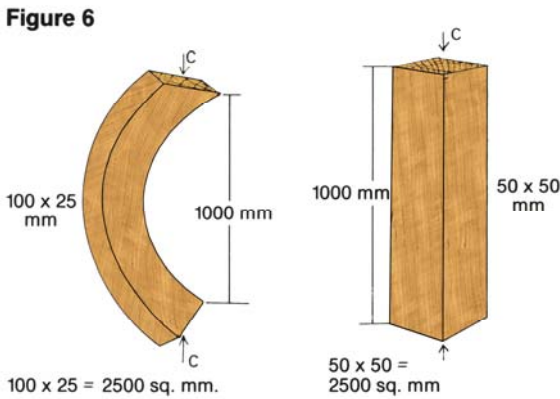

column, given that the cross-sectional area is the same.

In the example of 100 x 25 member having a cross sectional area of 2500 mm is not as strong in compression as a 50 x 50 member, provided that the other factors of length and material strength are equal.

**Figure 7**

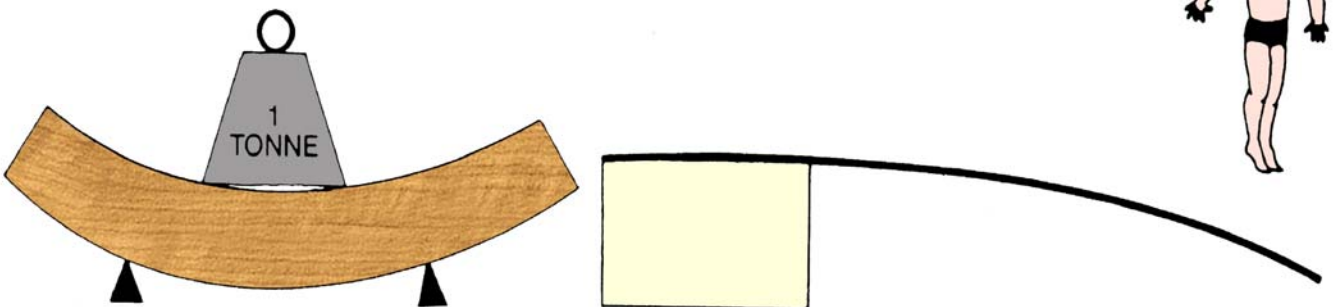

**Bending** force, or more correctly bending moment, is the result of a force applied to a cantilever, for example: a diving board, or to a simple beam.

The load carrying capacity of a beam is dependent upon the strength of the material and also the cross-sectional shape of the beam. In the case of the beam, unlike the column, the deeper section having the same cross-sectional area will be the stronger member in bending. Beams subject to bending moments also require lateral restraints, as with columns.

The deeper the beam the greater number of restraints required.

**Figure 8**

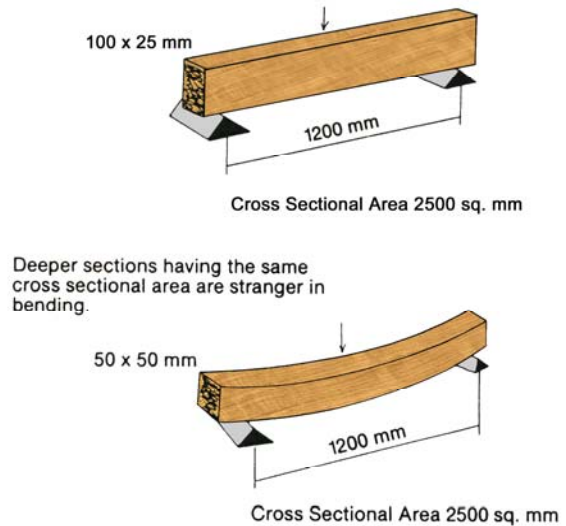



**Forces in Members.**

In many common types of trusses it is possible to identify the type of force which is in any particular member without undertaking any calculations.

The example in figure 9 is a common 'A' type gable truss with a uniformly distributed load along the top and bottom chords. This is due to the transfer of the load of the tiles through the tile battens and the ceiling load through the ceiling battens.

This means that the chords are subjected to bending forces as well as compression and tension forces. This loading arrangement would result in the top chord restraining compression plus bending forces. The short web is in compression and the long web is in tension. The geometry of both 'A' & 'B' type gable trusses is arranged so that under normal conditions, the longer webs are in tension and the shorter webs in compression. This is done to economise on the size of the timber required for the compression webs.

**Figure 9**

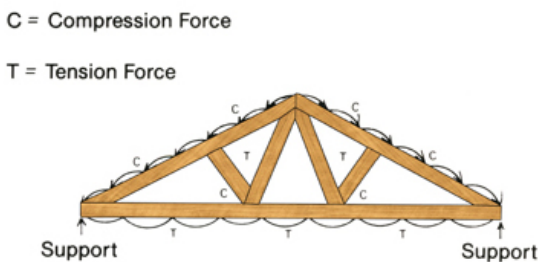

**Deflection.**

Wherever a member is subjected to a tension, compression or bending force (bending moment), the member is deformed by the force, irrespective of how strong the material is or how large the section. The amount of deformation does, however, depend on material strength and the size and shape of the section.

In Figure 10a it can be seen that the Oregon beam would deflect 32 mm soon after the one tonne point load is applied at a mid-span. If this load is maintained, the deflection may gradually increase to three times the initial deflection after a period of 20 to 24 months. This increase in deflection, with time, without increase in load, is called "creep". This characteristic is significant with timber, but can be ignored in other structural materials like steel.

**Figure 10a**

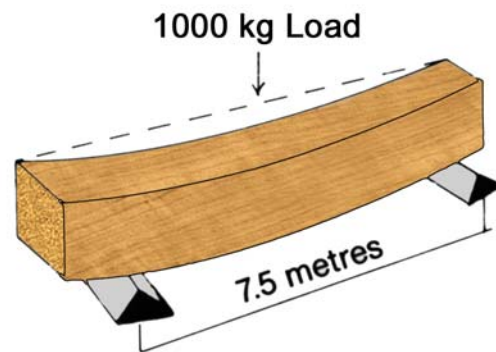

**350 x 75 OREGON BEAM**

If the same load is applied to a steel universal beam (see Figure 10b), the spontaneous deflection is approximately 1 mm. The long term deflection will also be 1 mm.

**Figure 10b**

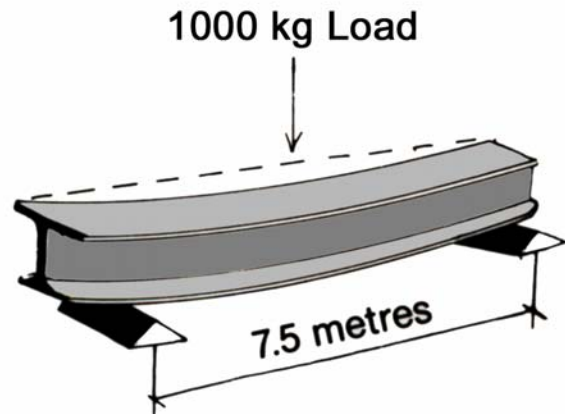

Instantaneous deflection = 1mm  
Long term deflection = 1mm

**310 x 165mm UNIVERSAL STEEL BEAM**

The timber truss (See Figure 10c) will also deflect under the same load, but because it is braced by its triangular web layout, it is much stiffer than the heavier Oregon beam, and is nearly as stiff as a large steel beam which would weigh approximately three times more, and would probably cost five times as much as the timber truss.

Figure 10c

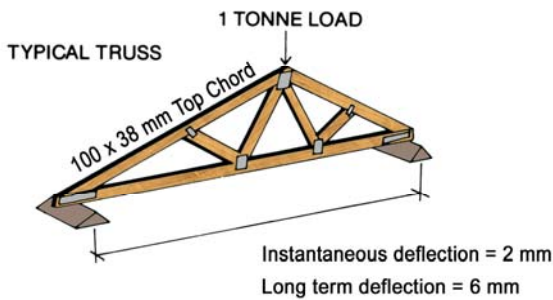

From these examples, it can be readily appreciated that timber trusses are very effective structural components.

### Camber

To compensate for deflection which occurs when loaded, trusses are manufactured with an upward bow which is called “camber”. Some deflection occurs as the truss is erected, more deflection will occur as the roof and ceiling loads are applied to the truss, and further deflection will occur over a period of time due to the “creep”.

Because the chords are subjected to a distributed load, they will also deflect in between panel points, in addition to the truss as a unit deflecting downwards.

This deflection of the chords is called “panel deflection” and cannot be compensated for during manufacture, as can be for truss deflection (camber). All standard truss layouts, are designed to keep panel deflection within acceptable limits.

Figure 11

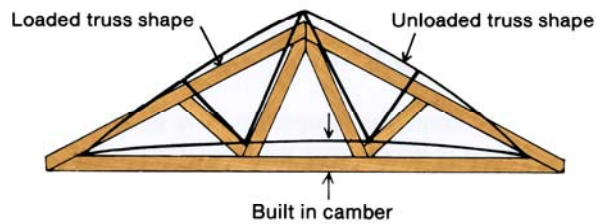

Trusses are cambered so that bottom chord becomes straight after a period of approximately 2 years

Figure 12

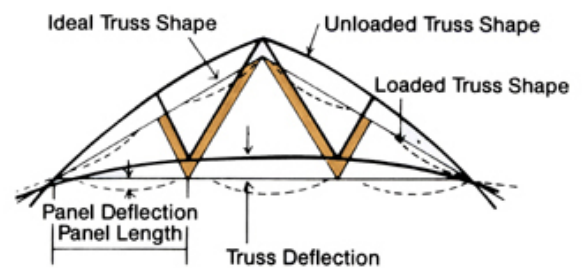

Exaggerated long term truss deformation under distributed top and bottom chord loads.

### Truss Analysis and Member Design

When the design loads are known and a truss shape has been chosen, the truss can be analysed to find the forces that will occur in each of its individual members. This process is done by computer using well-established methods of structural mechanics. The computer uses a process of analysis that is integrated with the selection of members of suitable size and stress grade and the calculation of expected deflection when loaded.

Truss members are subjected to combinations of bending, shear and compression or tension. The combinations can vary during the life of the structure as different loading conditions occur and every foreseeable situation has to be considered. Timber members are chosen so that they meet the strength and serviceability requirements of AS 1720.1 ‘Timber Structures Part 1 - Design Methods’ for each load case.

## **GANG-NAIL CONNECTORS - HOW THEY WORK**

A Gang-Nail connector is a steel plate with a collection of spikes or nails projecting from one face. The spikes, or teeth, are formed by punching slots in steel but leaving one end of the 'plug' connected to the sheet. The teeth are then formed so they project at right angles to the plate. During this process the teeth are shaped to produce a rigid projection. When the teeth of a connector plate are pressed into timber laid end-to-end, the plate 'welds' them together by forming a Gang-Nail joint. Connectors are always used in pairs with identical plates pressed into both faces of the joint.

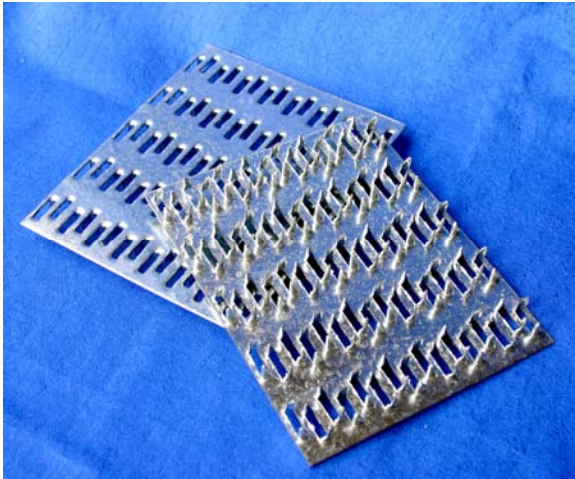

The concept is simple but the design of efficient Gang-Nail connectors requires careful balancing of tooth shape and density, connector plate thickness and ductility. An ongoing commitment to research and development ensures that MiTek's licensed truss fabricators have the most efficient truss system at their disposal.

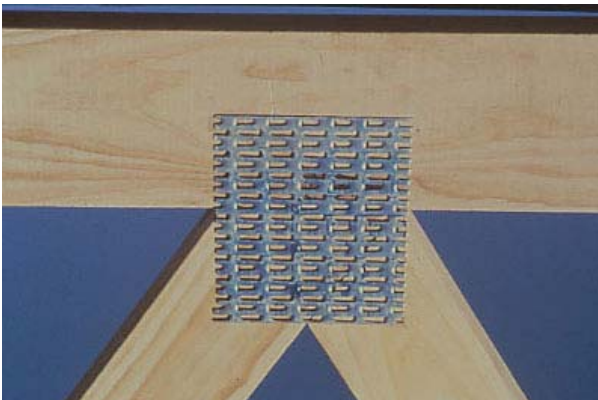

### **Performance criteria for Gang-Nail connectors**

It is not economical to have a single connector that gives optimum performance under all loading conditions, for all of Australia's wide range of commercial timbers. MiTek Australia Ltd. has developed a complementary range of connector plates of varying plate thickness (gauge), tooth layout and tooth profile. These are:

GQ – 20 gauge (1.0 mm thick) galvanised steel. General purpose connector. Many short, sharp teeth - 128 teeth in a 100 mm x 100 mm area.

GE - 18 gauge (1.2mm thick) galvanized steel. Similar to GQ. For use when additional steel strength is required.

G8S – 18 gauge (1.2 mm thick) stainless steel. This connector is only used when the environment is highly corrosive. 70 teeth in a 100 mm x 100 mm area.

GS – 16 gauge (1.6 mm thick) galvanised steel. Heavy duty connector. 144 teeth in a 100 mm x 190 mm area.

### **Engineering Data**

Gang-Nail connector properties have been established in accordance with Australian Standard AS1649 'Timber - methods of test for mechanical fasteners and connectors - Basic working loads and characteristic strengths. As well as testing new plate designs, MiTek Australia Ltd. conducts regular tests on their existing connector range and monitors the long term behaviour of joints subjected to constant loading. The CSIRO Division of Forest Products and the NSW Forestry Commission Division of Wood Technology have also done considerable research work on toothed metal plate connectors.

Full scale truss testing programs have also been carried out at the Universities of Western Australia and Adelaide, Australian National University and the Cyclone Testing Station at Capricornia Institute of Advanced Education.